

# Conforama

NOTICE DE MONTAGE  
**ASSEMBLING INSTRUCTIONS**  
 ISTRUZIONI DI MONTAGGIO  
**MONTAGEANLEITUNG**  
 INSTRUCOES DE MONTAGEM  
**MANUAL DE MONTAJE**  
 UPUTE ZA MONTAŽU  
 MONTAJ TALIMATLARI



## STAIR CRIV. 84 X 48 X 187 / LDAWS 85

25-03-2018



60  
MN

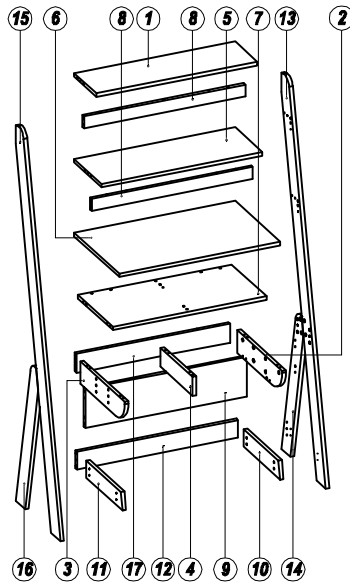
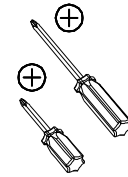
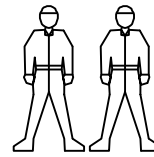

AVANT DE COMMENCER, SE  
 REPORTER AUX CONSEILS  
 DE MONTAGE EN ANNEXE

**BEFORE STARTING, REFER  
 TO THE ASSEMBLING ADVISE  
 IN ANNEX**

AVANTI DI COMINCIARE,  
 RIPORTATE AGLI CONSIGLI DI  
 MONTAGGIO

**VOR DIE MONTAGE, BITTE  
 BEILIEGENDE ANWEISUNGEN  
 FOLGEN**

ANTES DE COMERCAR, ADIAR-  
 SE AOS CONSELHOS DE  
 MONTAGEM EM ANEXO

**ANTES DE EMPEZAR  
 CONSULTE LOS CONSEJOS  
 PARA EL MONTAJE**

PRJE POČETKA MONTAŽE  
 MOLIMO PAŽLJIVO  
 PROČITAJTE UPUTE ZA  
 MONTAŽU

**BAŞLAMADAN ÖNCE,  
 EKTEKI MONTAJ  
 TAVSİYELERİNİ İNCELEYİN**

<b>A</b> x 32 	<b>B</b> x 36 	<b>C</b> x 6 	<b>D</b> x 47  Ø 7.8 X 32 mm	<b>E</b> x 4  Ø 7.8 X 25 mm	<b>F</b> x 2  Ø 7.8 X 40mm
<b>G</b> x 8 	<b>H</b> x 4 	<b>J</b> x 8 	<b>K</b> x 4 	<b>L</b> x 4 	<b>M</b> x 8 
<b>N</b> x 1 	<b>P</b> x 2  Ø 3.5 x 12 mm	<b>Q</b> x 8 			

### FRANCE

CODE INFORMATIQUE

### SWITZERLAND

CODE INFORMATIQUE  
 INFORMATIK CODE  
 CODICE INFORMATICO

### ESPAÑA

CODIGO INFORMATICO

### TÜRKİYE

BILGISAYAR KODU

### PORTUGAL

CODEGO INFORMATICO

### ITALIA

CODICE INFORMATICO

88079

SANREMO LIGHT

### CROATIA

CODE INFORMATIQUE

1

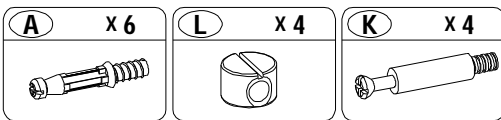
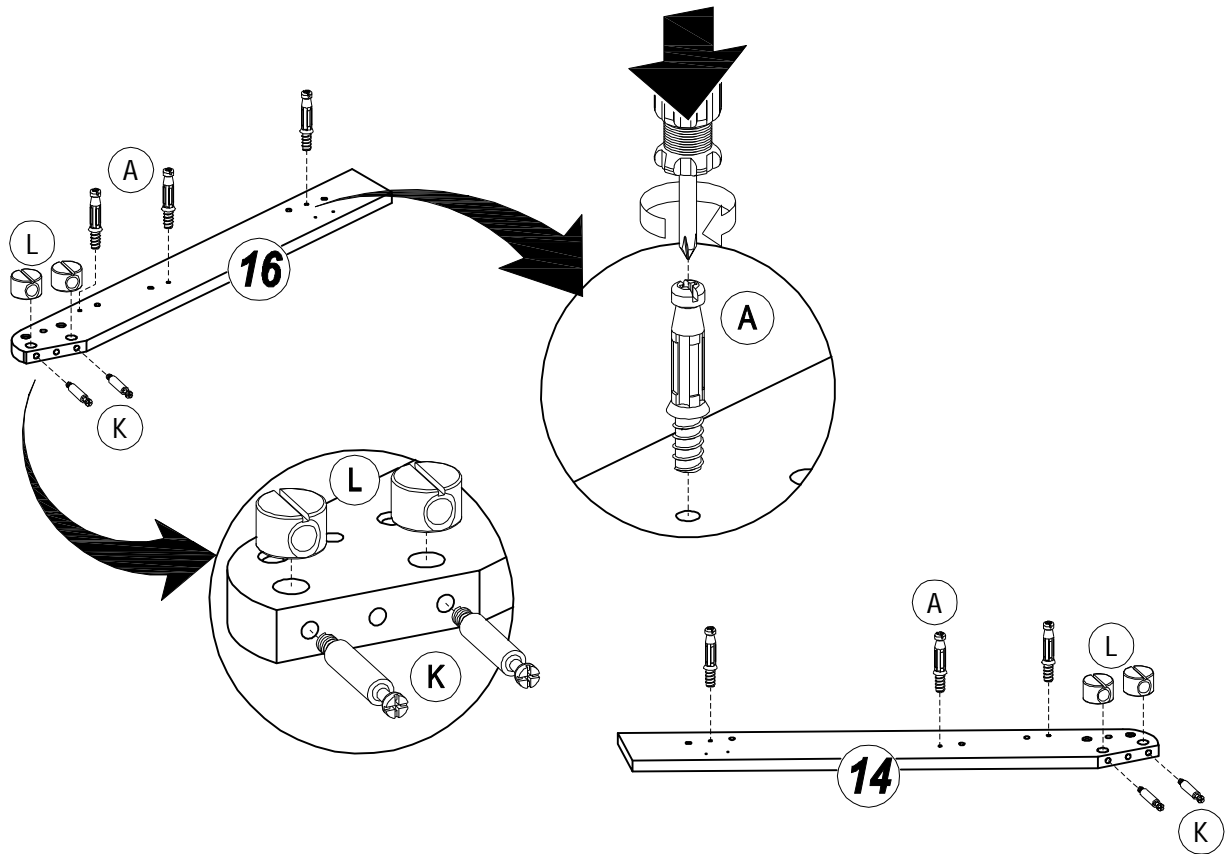

2

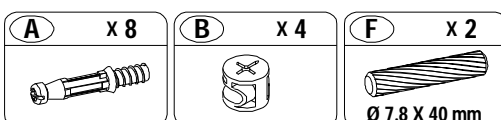
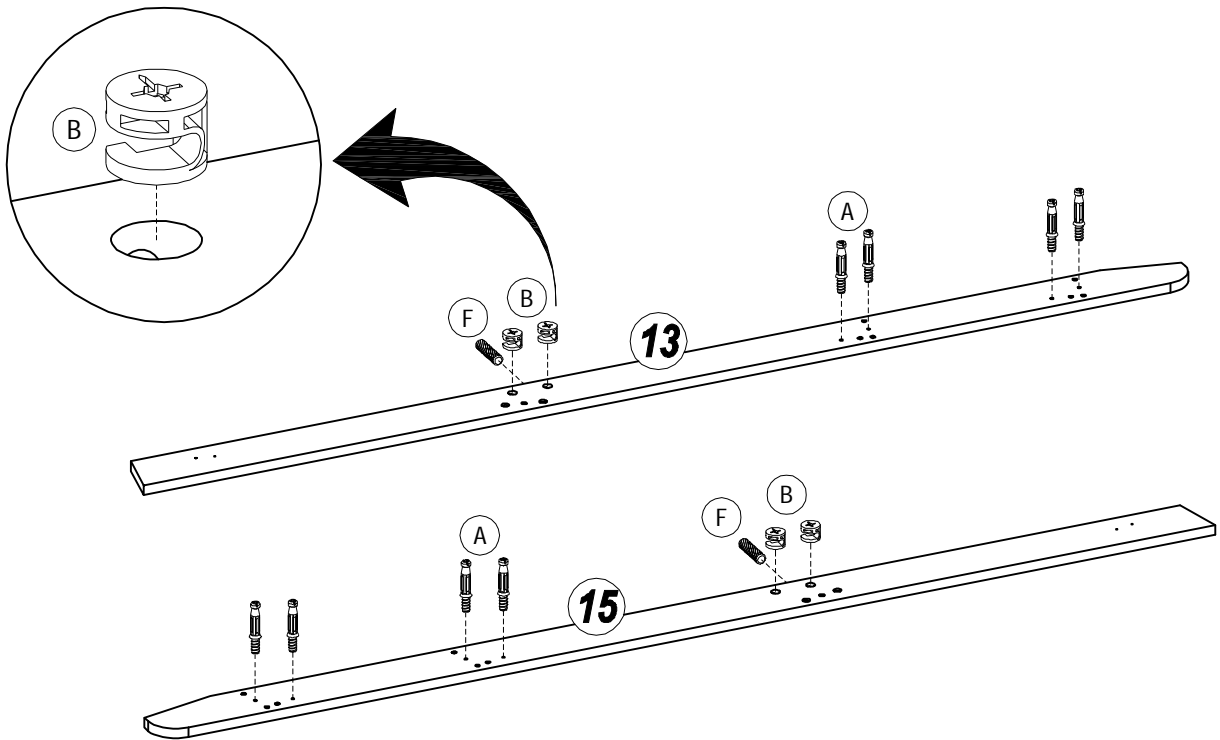

3

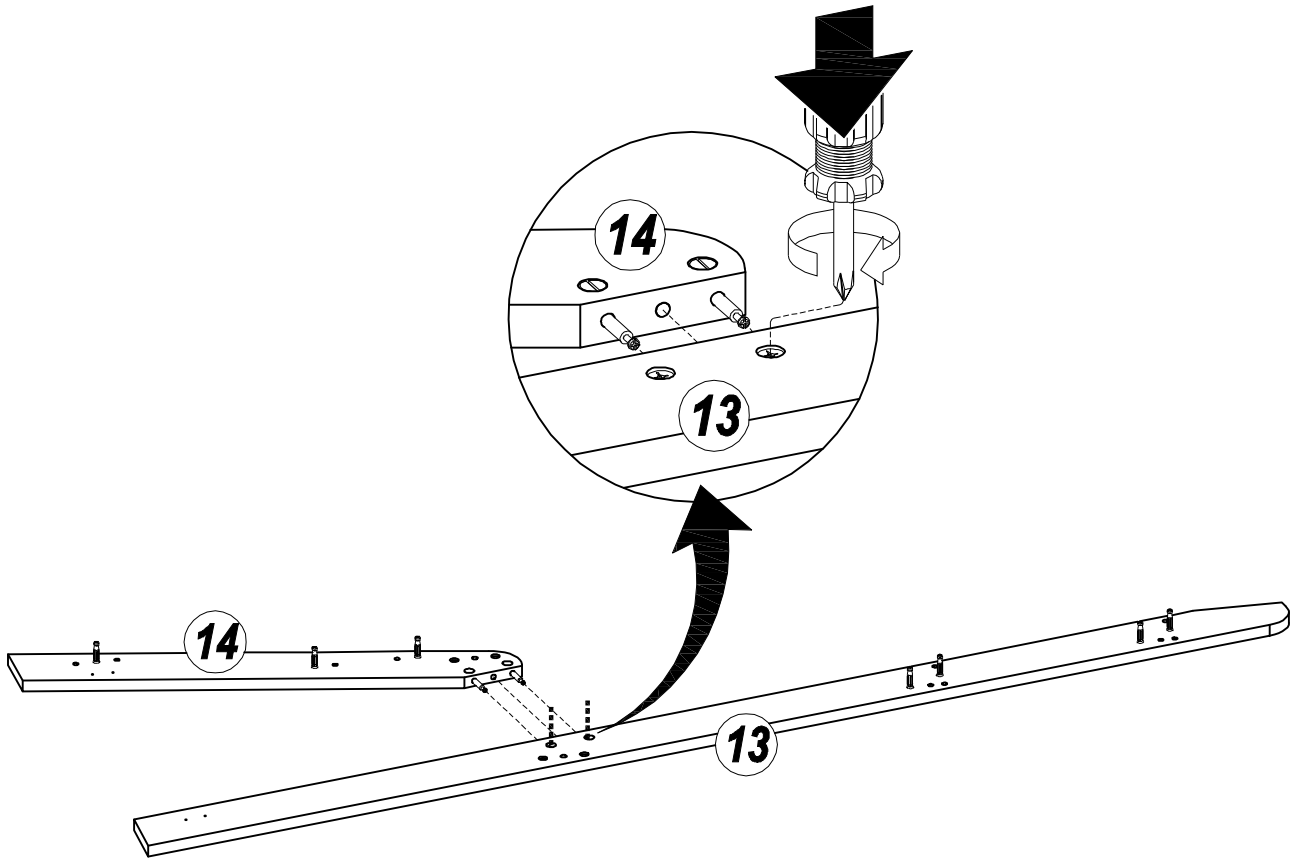

4

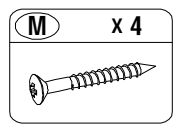
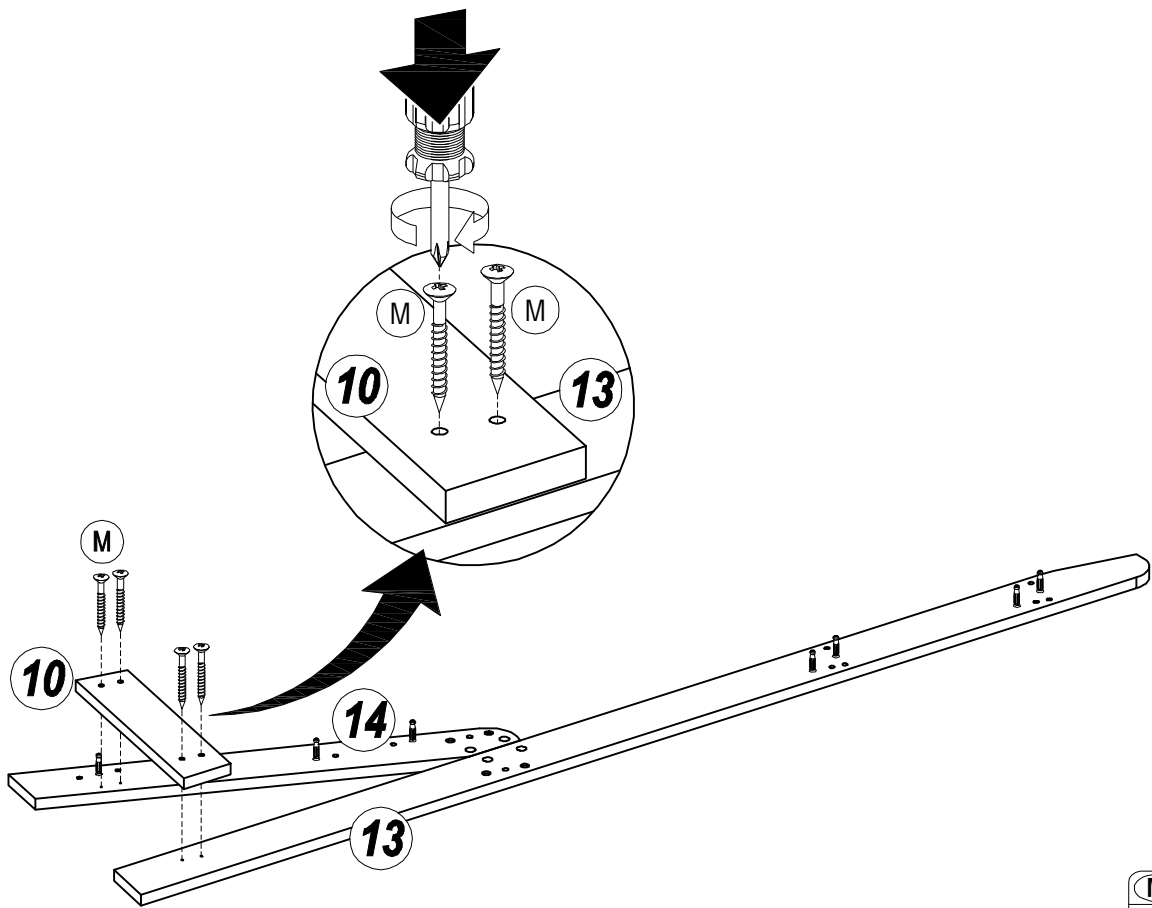

5

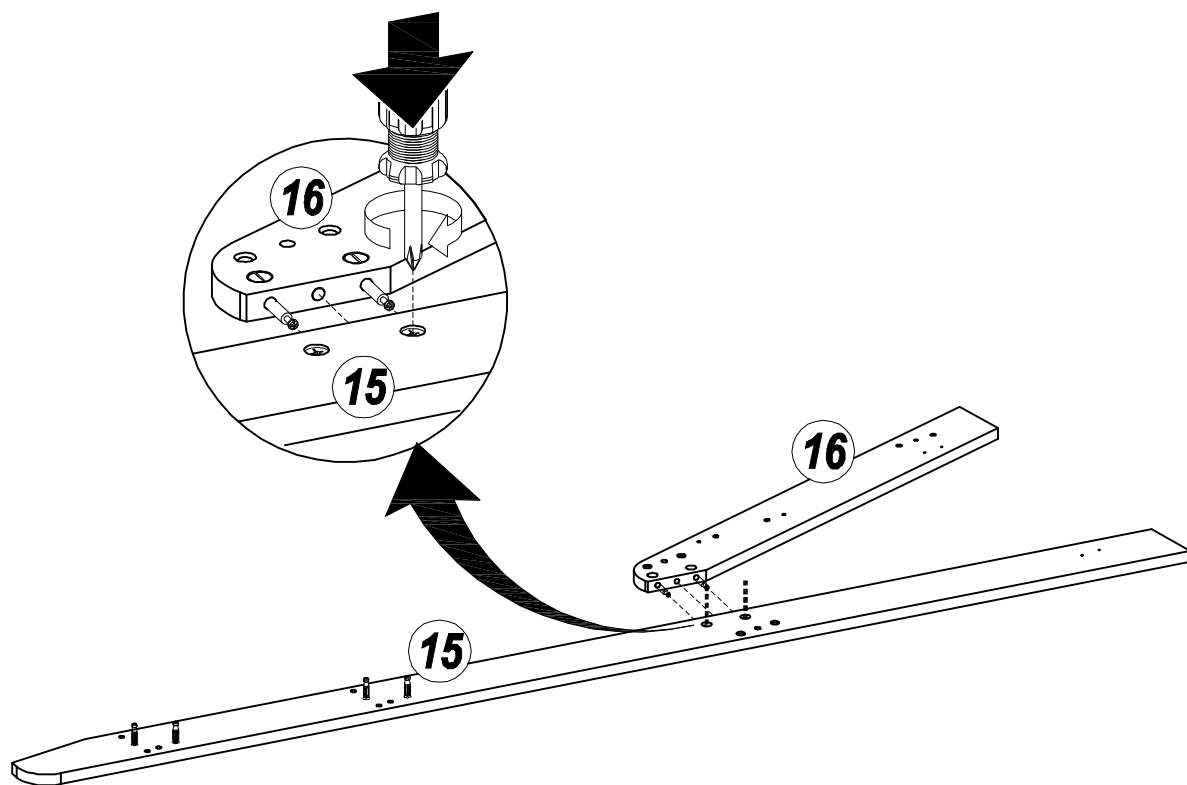

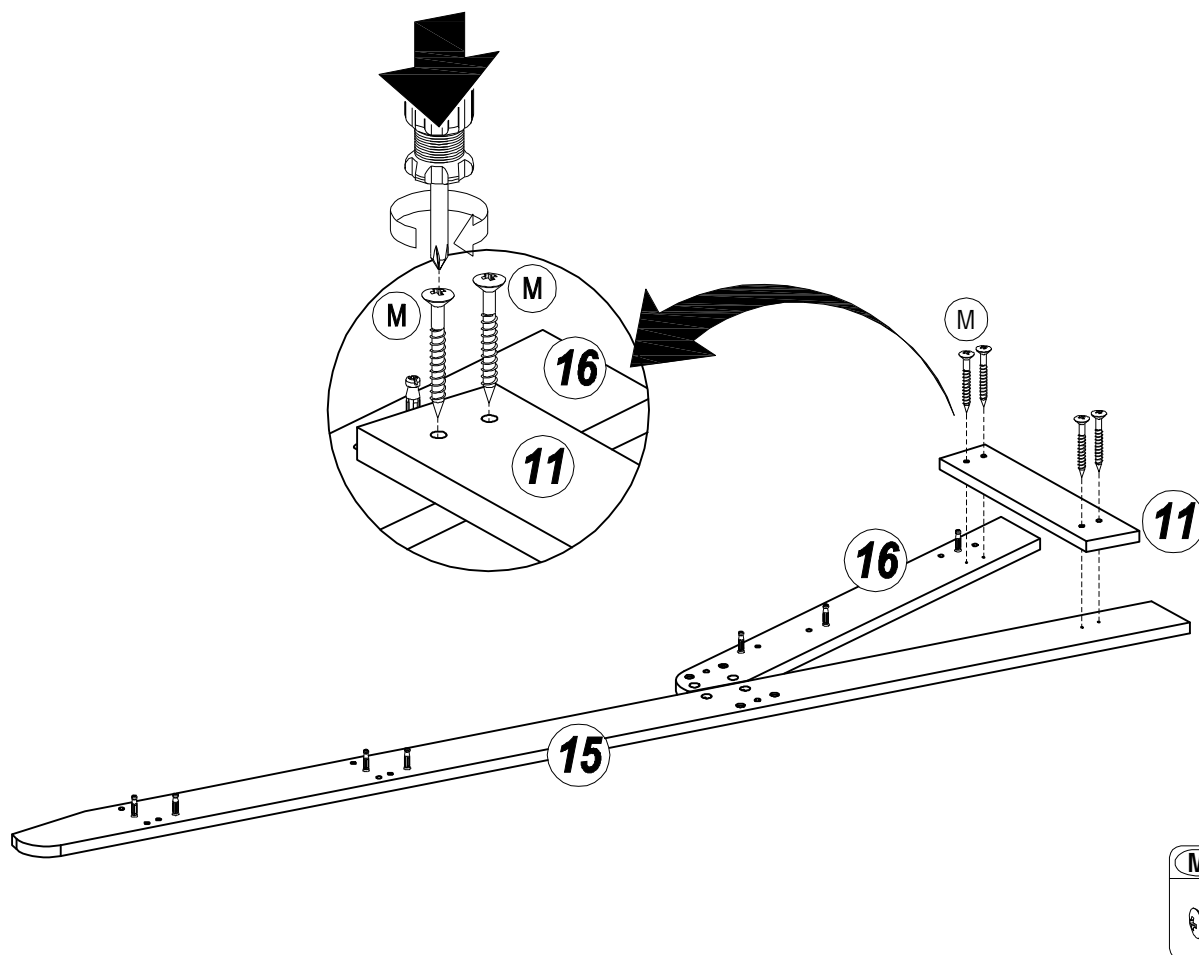

6



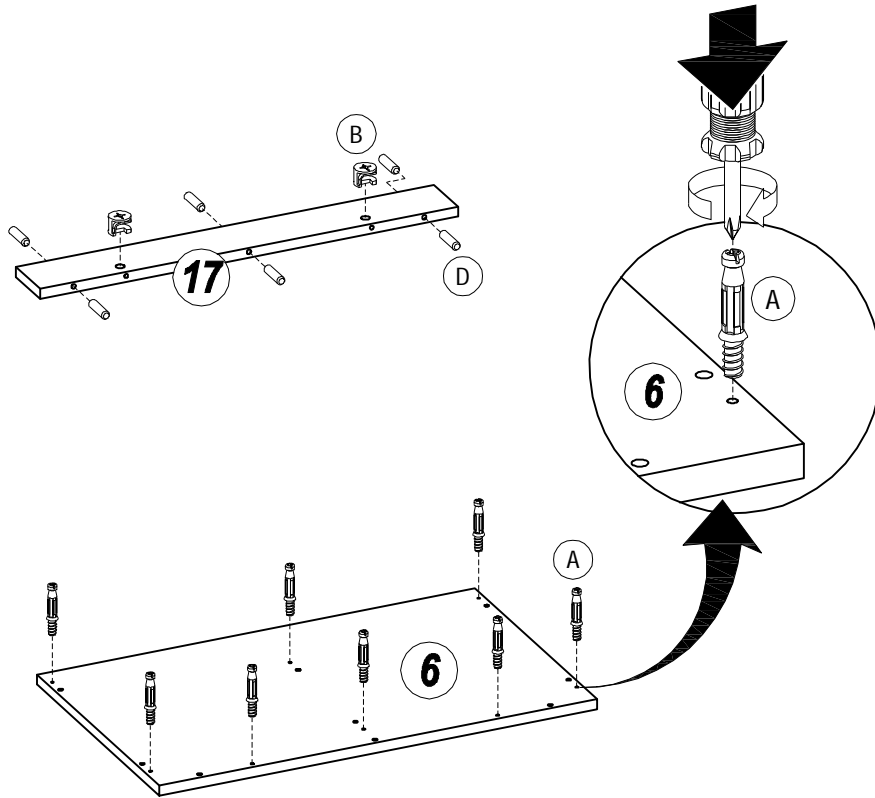

7

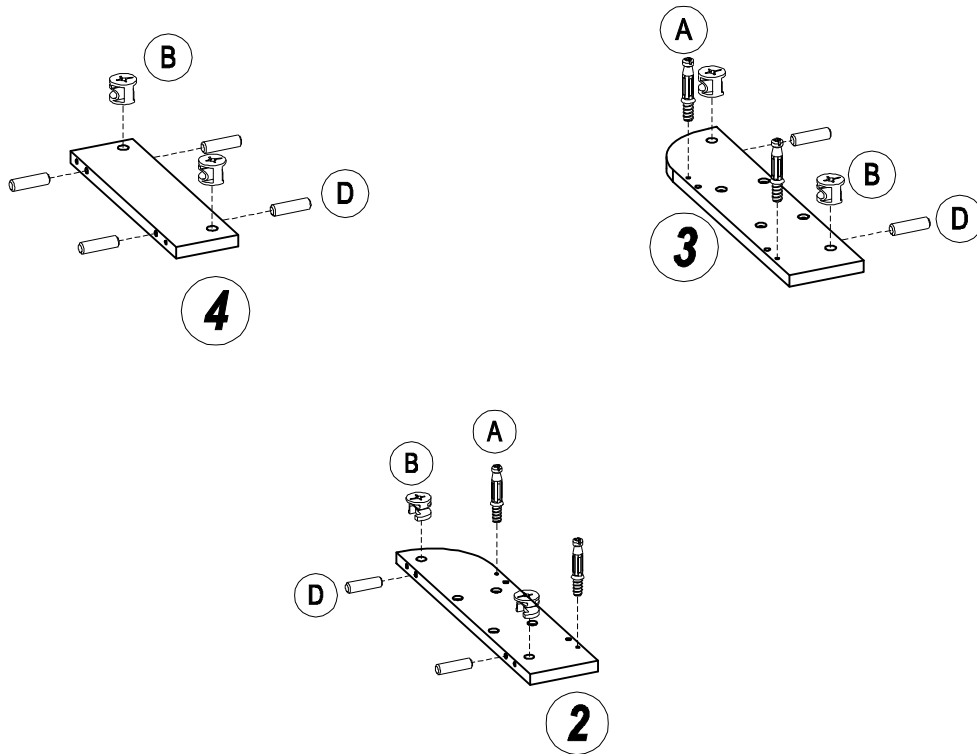

<b>A</b> x 8	<b>B</b> x 2	<b>D</b> x 6
		
		Ø 7.8 X 32 mm

8

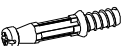

<b>A</b> x 4	<b>B</b> x 6	<b>D</b> x 8
		
		Ø 7.8 X 32 mm

9

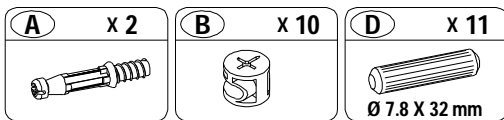
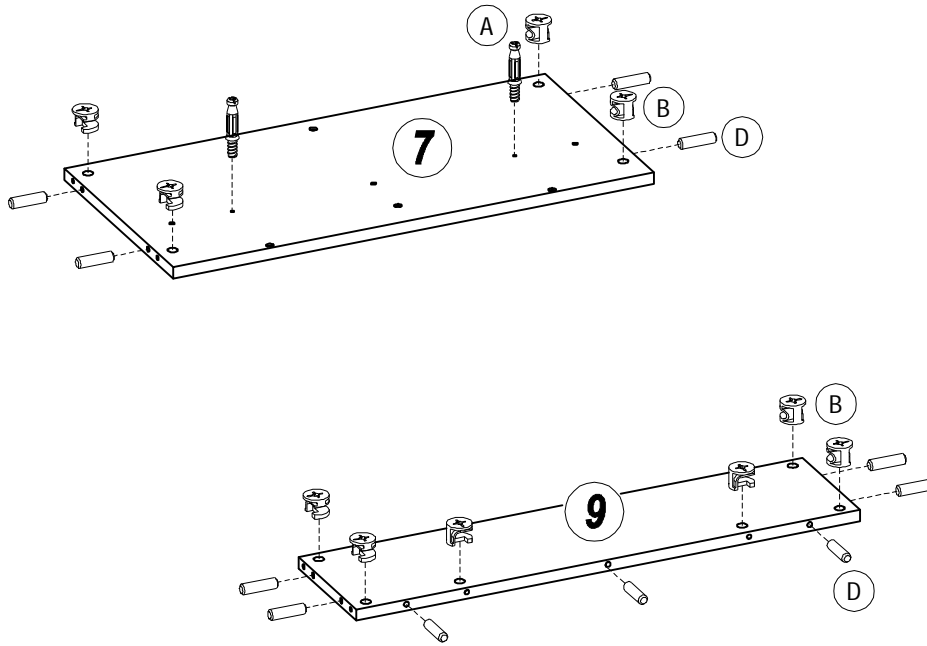

10

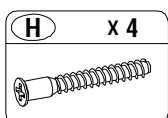
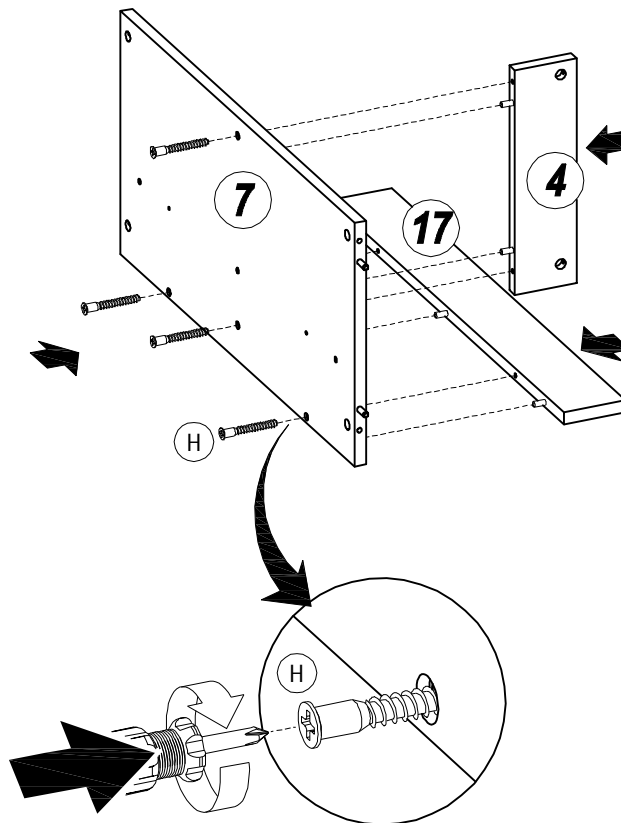



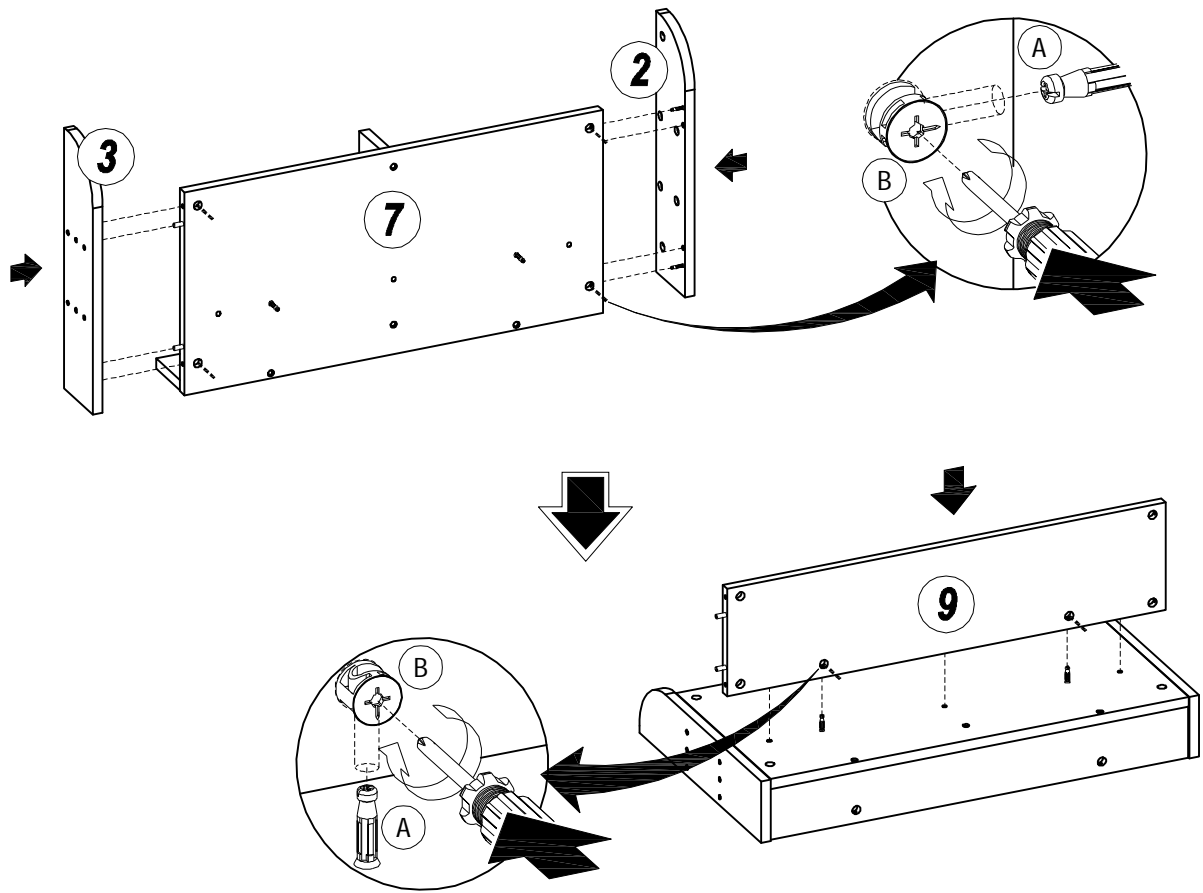

11

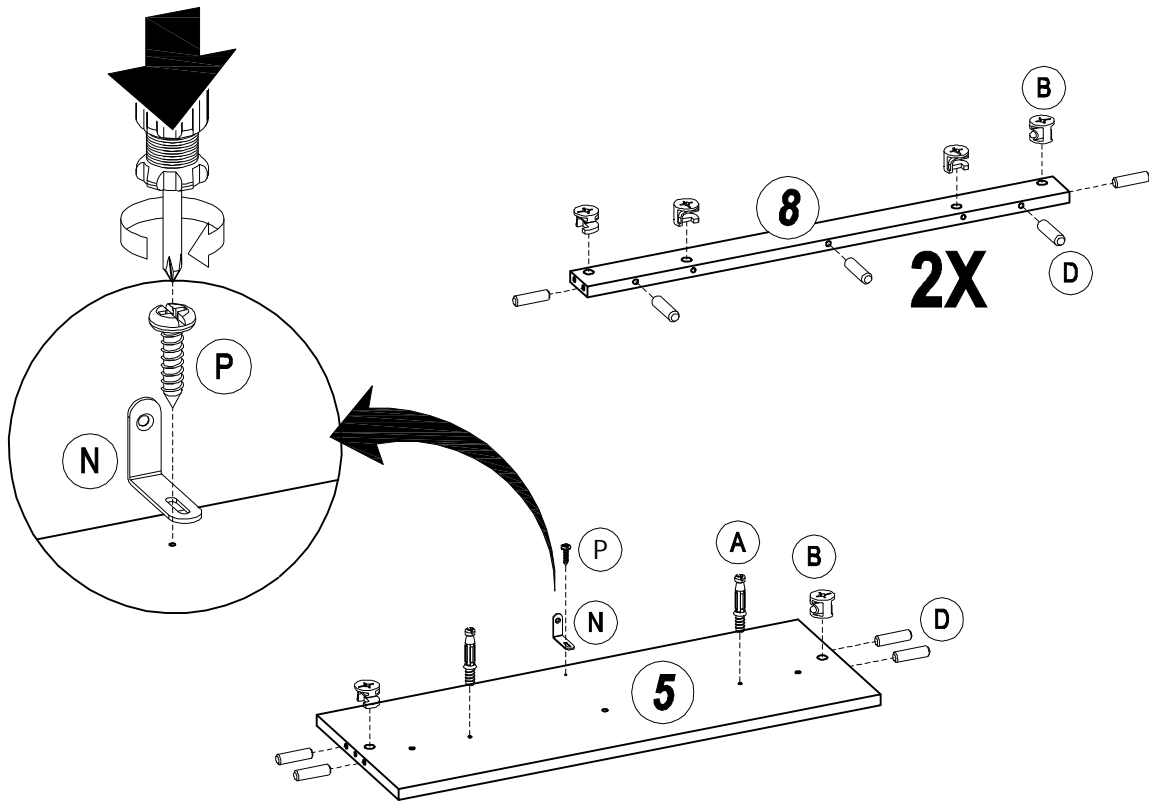

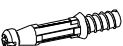
12



<b>A</b> x 2	<b>B</b> x 6	<b>D</b> x 14	<b>N</b> x 1	<b>P</b> x 1
		 Ø 7.8 X 32 mm		 Ø 3.5 X 12 mm

13

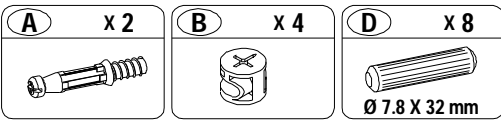
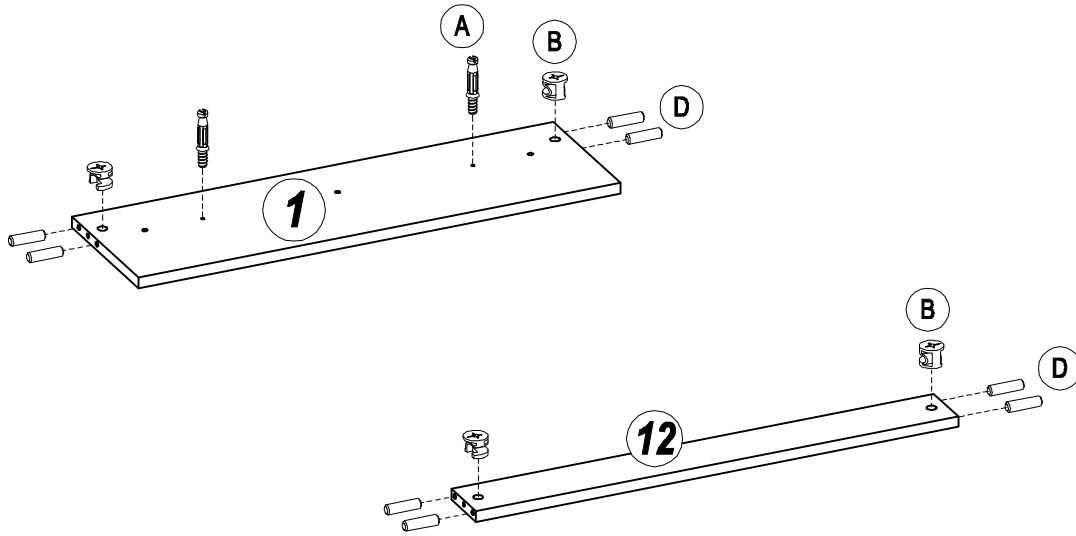

14

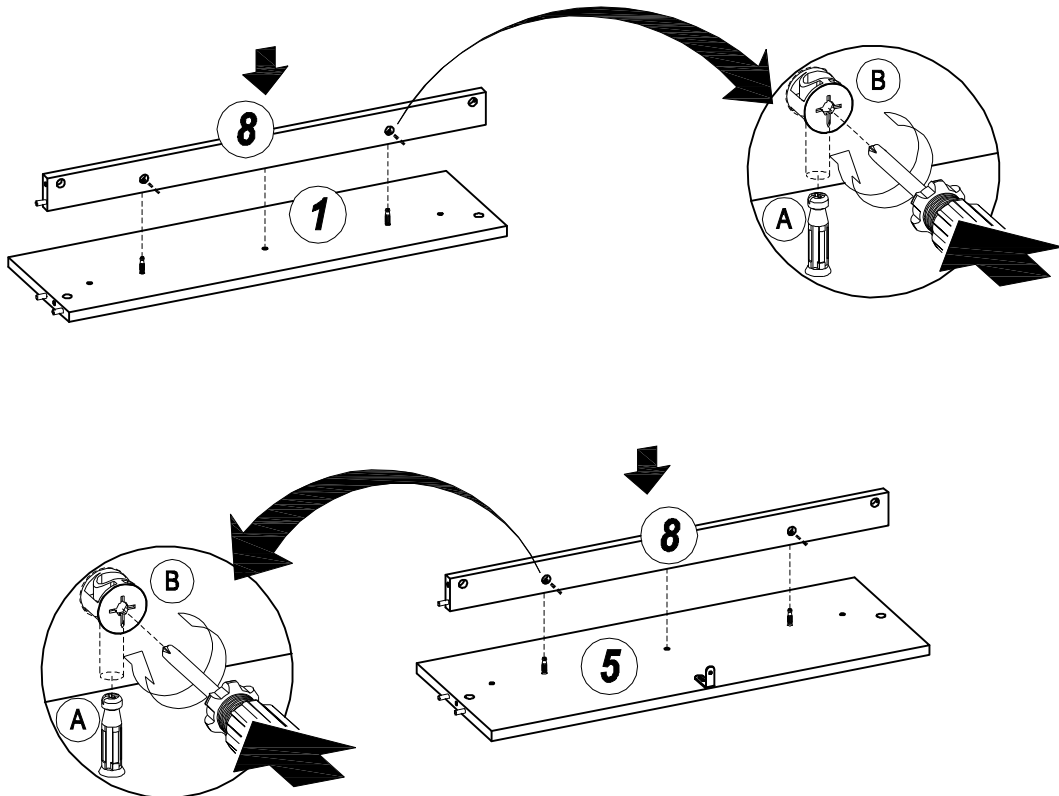



15

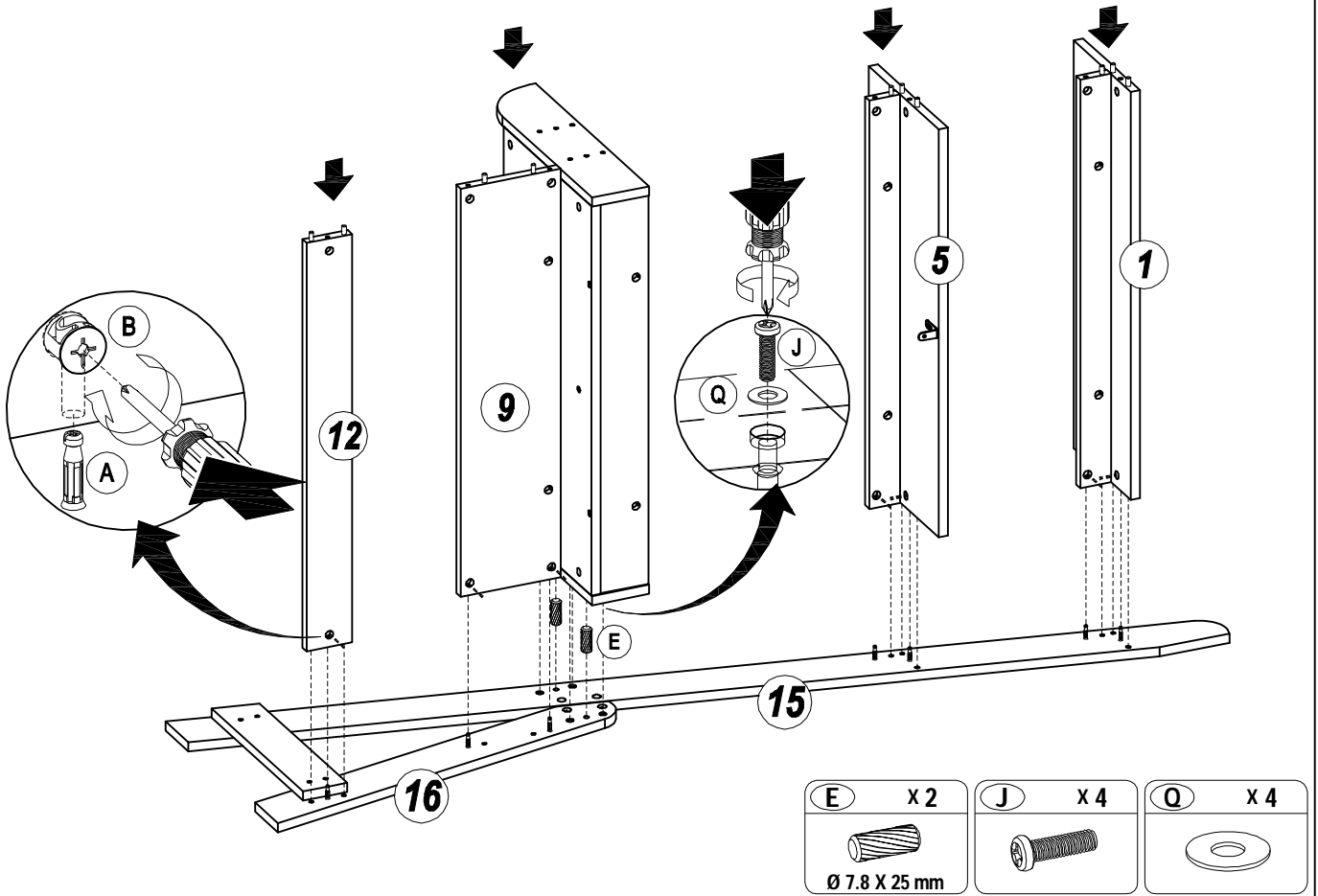

16

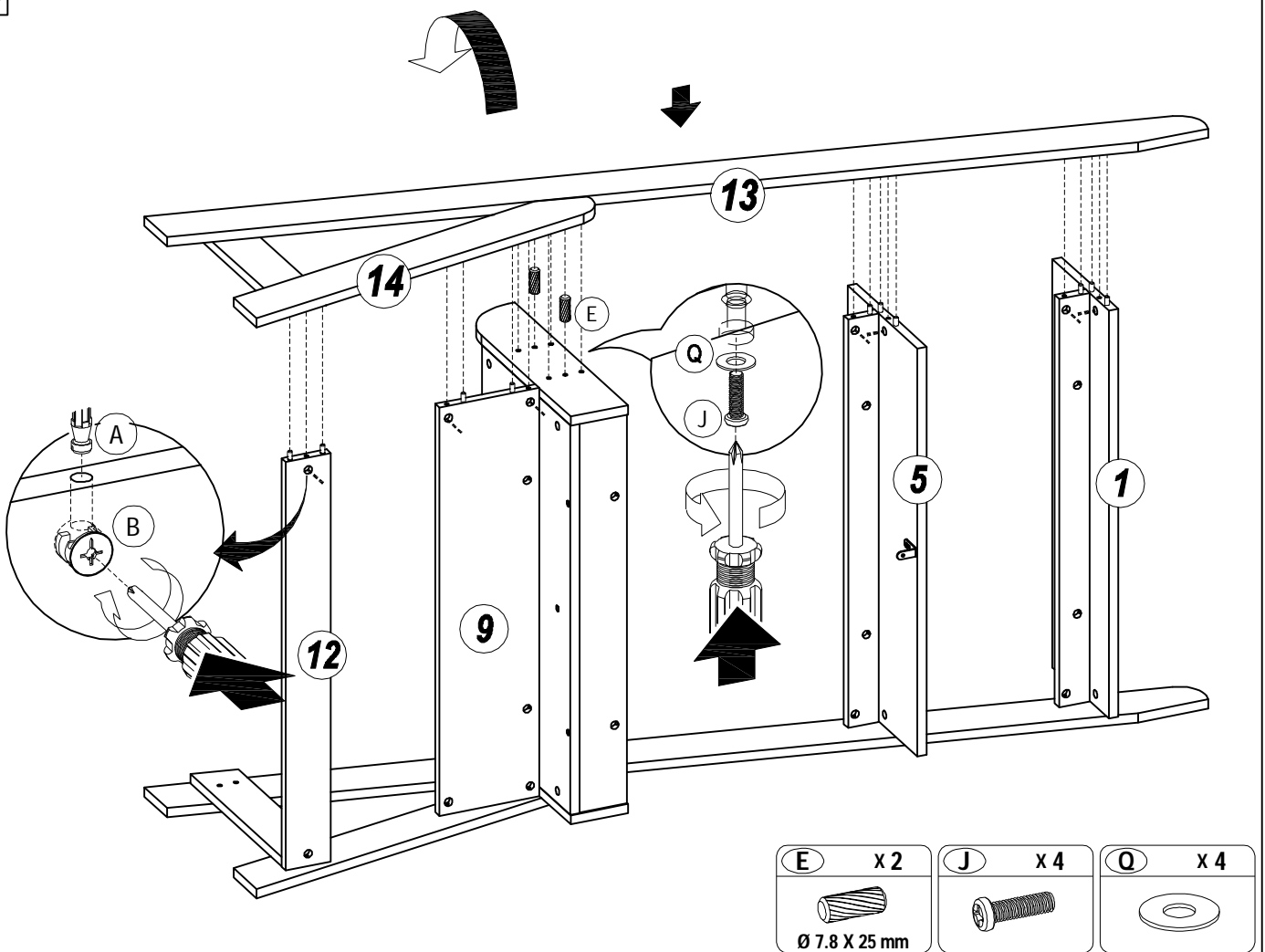

17

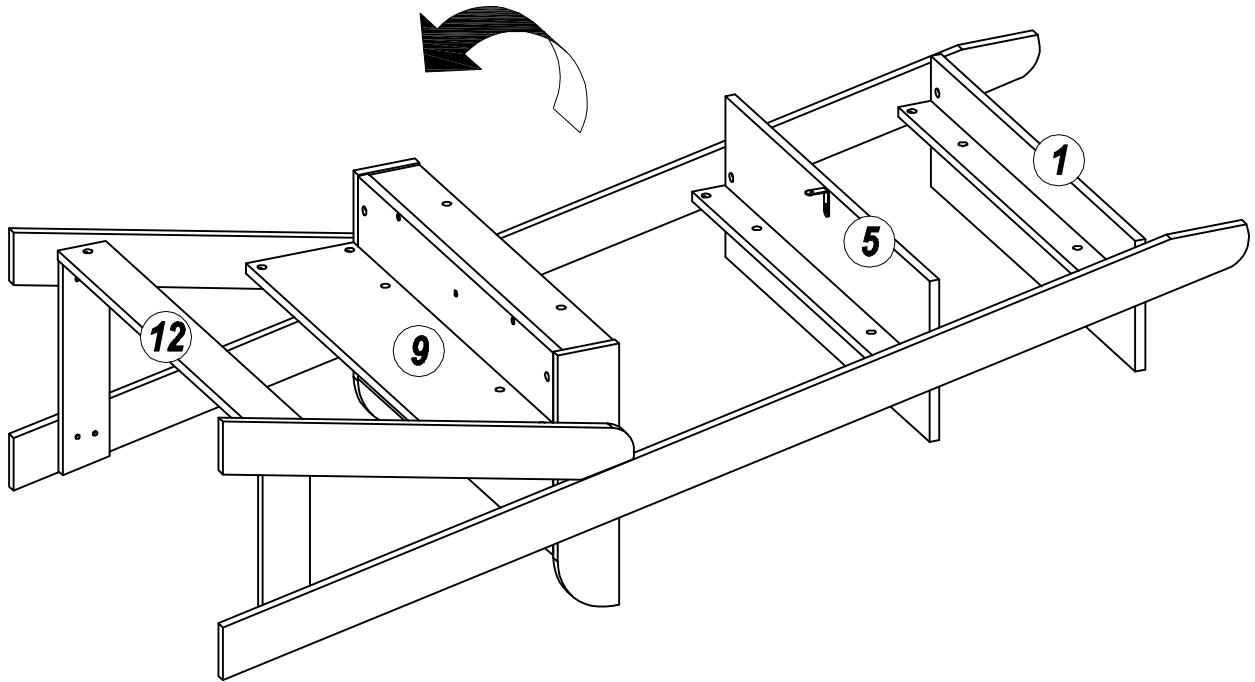

18

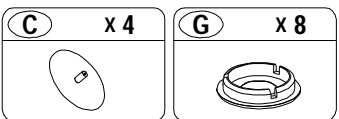
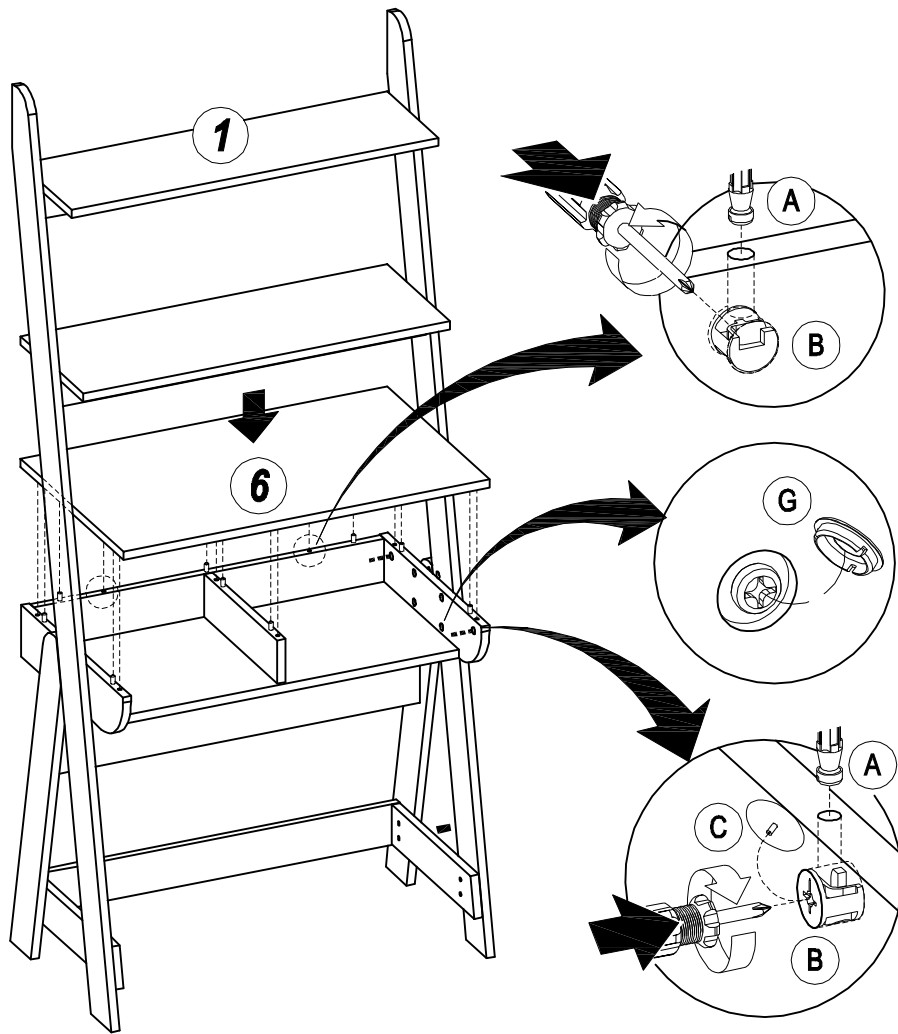

19

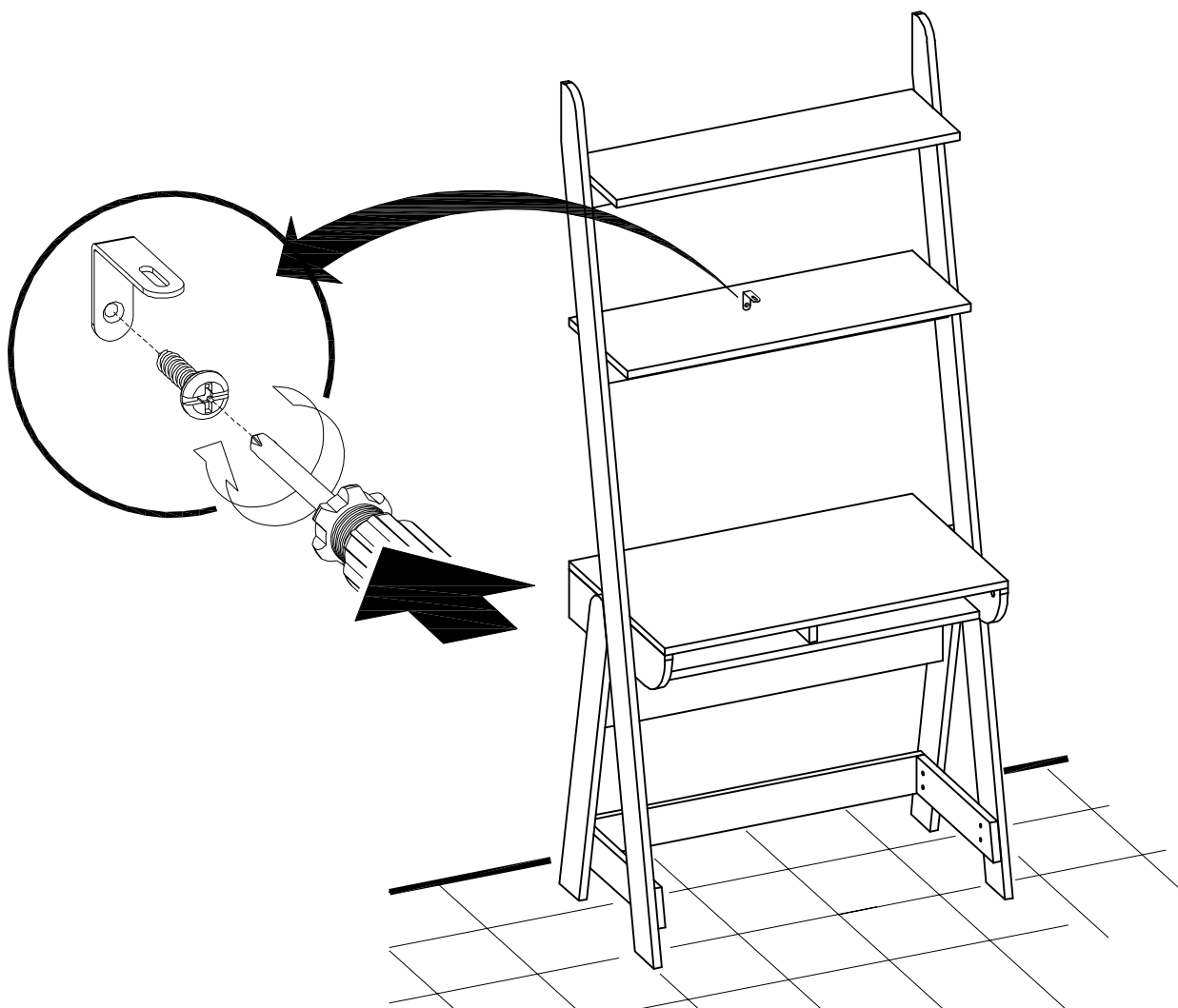
**IMPORTANT :**

THIS FURNITURE MUST BE FIXED TO THE WALL WITH THE ENCLOSED WALL FASTENER. NON USE OF THE WALL FASTENER MAY CAUSE THE PRODUCT TO MOVE AND POSSIBLY LEAD TO DAMAG AND / OR INJURY IMPROPERLY FITTED.

IF IN DOUBT CONSULT A QUALIFIED TECHNICIAN AT YOUR DIY / HOME IMPROVEMENT STORE.

DIFFERENT WALL MATERIALS REQUIRE DIFFERENT TYPES OF FIXING DEVICES.

USE FIXING DEVICES SUITABLE FOR THE WALLS IN YOUR HOME (NOT INCLUDED), IF YOU ARE UNCERTAIN ABOUT WHAT TYPE OF SCREW OR FITTING TO USE, PLEASE CONTACT YOUR HARDWARE STORE.

(Ce meuble doit être fixé au mur avec l'accessoire de fixation murale inclus. Ne pas utiliser la fixation murale peut provoquer la chute du produit et éventuellement conduire à des dommages et / ou des blessures . En cas de doute, consultez votre magasin.)

(Matériaux des murs nécessitent différents types de dispositifs de fixation. Utiliser des dispositifs de fixation appropriés pour les murs de votre maison (non inclus). Si vous n'êtes pas sûr de ce type de vis ou d'un raccord à utiliser, veuillez s'il vous plaît contactez votre magasin.)

French

**IMPORTANT:** Pour éviter le basculement accidentel du meuble, la fixation du meuble au mur est obligatoire.  
La visserie nécessaire pour la jonction mur/meuble, dépendante de la nature du mur, n'est pas fournie.  
En cas de doute, consulter un spécialiste

English

**IMPORTANT:** To avoid the accidental tip-over of the furniture, the fixing of the furniture on the wall is mandatory.  
The needed hardware for the junction wall/furniture, depending of the nature of the wall, is not provided.  
If any doubt, consult a specialist.

Spanish

**IMPORTANTE:** Para evitar el vuelco accidental de los muebles, es obligatorio fijarlos en la pared.  
El tipo de tornillos necesarios para fijar el mueble a la pared, dependen del material de la pared, no se suministran.  
En caso de duda, consulte a un especialista.

Portuguese

**IMPORTANTE:** Para evitar a queda acidental de móveis, é obrigatorio fixá-los na parede.  
O tipo de parafusos para a fixação de mobiliário na parede, depende do material de parede e não são fornecidos.  
Em caso de dúvida, consulte um especialista.

Italian

**IMPORTANTE:** Per evitare il ribaltamento accidentale del mobile è obbligatorio il fissaggio a muro.  
I tasselli necessari per il collegamento mobile\muro, dipendenti dal tipo di muro, non sono provvisti.  
Consultare uno specialista in caso di dubbi

Croatian

**VAŽNO:** Kako bi se izbjeglo slučajno prevrtanje, namještaj je potrebno pričvrstiti na (uza) zid.  
Različite vrste zidova zahtijevaju upotrebu različitih vrsta vijaka i tipli. Uvijek koristiti one koji su prikladni za vrstu zidova u domu. Vijci i tiplje prodaju se zasebno.  
U slučaju bilo kakvih sumnji, obratite se stručnjaku.

German

**WICHTIG :** Um ein versehentliches Kippen des Möbels zu vermeiden, ist die Befestigung an der Wand zwingend vorgeschrieben.  
Die benötigten Schrauben zur Wandbefestigung, welche von der Beschaffenheit der Mauer abhängen, sind nicht in der Lieferung enthalten.  
Wenden Sie sich bitte bei Zweifel an einen Spezialisten.

# Conforama

## FRANCAIS - SUISSE

### CONSEILS DE MONTAGE :

- 1 > BIEN ETUDIER LA NOTICE DE MONTAGE.
- 2 > REPEREZ LES PIECES CONSTITUANT VOTRE MEUBLE.
- 3 > REGROUPEZ ET CONTROLEZ LA QUINCAILLERIE.
- 4 > MUNISSEZ -VOUS DE L'OUTILLAGE NECESSAIRE.
- 5 > AMENAGEZ - VOUS UNE ZONE DE MONTAGE.
- 6 > PROCEDEZ AU MONTAGE.



NE JAMAIS FORCER LES ASSEMBLAGES.  
RESSERREZ LES VIS APRES QUELQUES TEMPS D'USAGE.  
GARDER VOTRE NOTICE DE MONTAGE, SI UNE PIECE  
VENAIT A MANQUER, ELLE SERAIT LE PLUS CLAIR  
MOYEN DE COMMUNIQUER AVEC VOTRE MAGASIN.

### CONSEILS D'ENTRETIEN :

- 1 > DÉPOUSSIÉREZ SOIGNEUSEMENT.
- 2 > HUMECTER UN CHIFFON DOUX ET PROPRE D'EAU LÉGÈREMENT SAVONNEUSE (OU DÉTERGENT).



- NE JAMAIS UTILISER  
DE PRODUITS ABRASIFS:  
POUDRE, LAINE D'ACIER, SOLVANTS.  
- NE PAS MOUILLER  
TROP COIEU SEMENT.

	PAPIER DECOR	SURFACES STRATIFIÉES	SURFACES LAQUÉES	BOIS VERNIS	TEXTILE CUIR
EAU SAVONNEUSE (SAVON NEUTRE)	○	○	○	○	○
EAU ADDITIONNÉE		○	○		
ENTRETIEN SPÉCIFIQUE FABRICANT					○

## DEUTSCH - SCHWEIZ

### MONTAGE ANLEITUNG :

- 1 > DIE MONTAGEANLEITUNG SORGFÄLTIG DURCHLESEN.
- 2 > DIE EINZELTEILE DES MÖBELSTÜCKS ERMITTELN.
- 3 > DIE BESCHLÄGE ZUSAMMENLEGEN UND PRÜFEN.
- 4 > DAS NOTWENDIGE WERKZEUG ZURECHTLEGEN.
- 5 > EINEN MONTAGEBEREICH FREIMACHEN.
- 6 > DAS MÖBELSTÜCK ZUSAMMENBAUEN.



NIEMALS DIE VERBINDUNGEN ZU STARK ANZIEHEN.  
DIE SCHRAUBEN NACH EINIGER ZEIT DES GEBRAUCHS  
ERNEUT FESTZIEHEN. DIE MONTAGEANLEITUNG  
GUT AUFBEWAHREN: SOLLTE EIN TEIL FEHLEN, IST SIE DAS  
BESTE VERSTÄNDIGUNG SMITTEL MIT IHREM GESCHÄFT.

### PFLEGEHINWEISE :

- 1 > SORGFÄLTIG ENSTSTAUBEN.
- 2 > MIT EINEM WEICHEN, SAUBEREN UND FEUCHTEM TUCH UND LEICHTER SELFENTAUGE REINIGEN.



- BENUTZEN SIE KEINE  
SCHEUERMITTEL WIE PULVER,  
STAHLWOLLE, LÖSUNGSMITTEL.  
- NICHT ZU NASS ABWISCHEN.

	DEKORPAPIER	OBERFLACHE LAMINAT	OBERFLACHE LACK	LACKIERTEM HOLZ	TEXTIL LEDER
SEIFENLAUGE (NEUTRALSEIFE)	○	○	○	○	○
WASSER MIT HAUSHALTSREINIGER		○	○		
PRODUZENT SPEZIFISCHER UNTERHALT					○

## ITALIANO - SVIZZERA

### CONSIGLI DI MONTAGGIO

- 1 > STUDIARE BENE LE ISTRUZIONI DI MONTAGGIO.
- 2 > PRENDERE CONOSCENZA DEI PEZZI CHE COSTITUISCONO IL MOBILE.
- 3 > RAGGRUPPARE E CONTROLLARE LA FERRAMENTA.
- 4 > MUNIRSI DEGLI UTENSILI NECESSARI.
- 5 > PREPARARE UNA ZONA DI MONTAGGIO.
- 6 > PROCEDERE AL MONTAGGIO.



NON FORZARE MAI GLI ASSEMBLAGGI  
RISTRINGERE LE VITI DOPO UN PERIODO D'USO  
CONSERVARE QUESTE ISTRUZIONI DI MONTAGGIO,  
SE UN PEZZO VENISSE A MANCARE SAREBBE IL MIGLIORE  
MEZZO DI COMUNICAZIONE CON IL RIVENDITORE

### CONSIGLI PER LA MANUTENZIONE :

- 1 > SPOLVERATE ACCURATAMENTE.
- 2 > INUMIDIRE CON ACQUA LEGGERMENTE INSAPONATA UNO STRACCIO MORBIDO E PULITO.



- NON UTILIZZARE MAI PRODOTTI  
ABRASIVI: POLVERE,  
LANA DI ACCIAIO, SOLVENTI.  
- NON BAGNARE TROPPO.

	CARTA	SUPERFICIE STRATIFICATE	SUPERFICIE LACCATE	LACCATE EGNO VERNICIATO	TESSILE CUIRO
ACQUA CON SAPONE (SAPONE NEUTRO)	○	○	○	○	○
ACQUA CON DETERSIVO SAN MARC		○	○		
MANUTENZIONE SPECIFICA PRODUTTORE					○

## ESPAÑOL

### CONSEJOS PARA EL MONTAJE :

- 1 > ESTUDIE ATTENTAMENTE EL MANUAL DE MONTAJE.
- 2 > LOCALICE LAS PIEZAS QUE CONSTITUYEN SU MEUBLE.
- 3 > REUNA Y CONTROLE LOS TORNILLOS.
- 4 > EQUIPE-SE DE LAS HERRAMIENTAS NECESARIAS.
- 5 > PREPARE UNA ZONA DE MONTAJE.
- 6 > REALICE EL MONTAJE.



NO FUERCE NUNCA EN LAS UNIONES. APRIETE LOS  
TORNILLOS DESPUES DE CERTO TIEMPO DE UTILIZACION  
CONSERVE SU MANUAL DE MONTAJE,  
SI FALTARA UNA PIEZA, SERIA LA MANERA  
MAS FACIL DE COMUNICAR CON LA TIENDA.

### CONSEJOS PARA EL MANTENIMIENTO :

- 1 > DESPOLVOREAR CULDADOSAMENTE.
- 2 > HUMEDECER UN PANO SUAVE Y LIMPIO CON AGUA LIGERAMENTE ENJABONADA.



- NO USE NUNCA PRODUCTOS  
ABRASIVOS TALES COMO:  
POLVO DE LIMPIAR,  
LANA DE ACERO, SOLVENTES.  
- NO MOJAR EXAGERADAMENTE.

	PAPEL DE DECORACION	SUPERFICIE ESTRATIFICADAS	SUPERFICIE MAQUEADAS	MADERA BARNIZADA	TEXTIL CUERO
AGUA Y JABON (JABON NEUTRO)	○	○	○	○	○
AGUA CON DETERGENTE		○	○		
MANTENIMIENTO ESPECIFICO DEL FABRICANTE					○

# Conforama

## PORTUGUÊS

### CONSELHOS DE MONTAGEM :

- 1 > ESTUDE BEM AS INSTRUÇÕES DE MONTAGEM.
- 2 > REUNA AS PEÇAS QUE CONSTITUEM O SEU MOVEL.
- 3 > REAGRUPE AS FERRAGENS.
- 4 > EQUIPE-SE COM AS FERRAMENTAS NECESSÁRIAS.
- 5 > PREPARE UMA ÁREA PARA A MONTAGEM.
- 6 > INICIE A MONTAGEM.

  
NUNCA FORÇAR OS ENCAIXES.  
REAPERTAR OS PARAFUSOS APÓS UM TEMPO DE UTILIZAÇÃO.  
GUARDAR AS INSTRUÇÕES DE MONTAGEM.  
CASO FALTE ALGUMA PEÇA, O MAIS ACONSELHÁVEL  
É CONTATAR O REVENDEDOR.

### CONSELHOS PARA A MANUTENÇÃO :

- 1 > ELIMINAR BEM O PÓ
- 2 > UMEDECER UM PANO SUAVE E LIMPO COM ÁGUA E UM POUCO DE SABÃO.

  
- NUNCA UTILIZAR PRODUTOS  
ABRASIVOS: SAPONÁCEOS,  
LÃ DE AÇO, SOLVENTES.  
- NÃO MOLHAR DEMASIADO.

	ACABAMENTO IMITAÇÃO	SUPERFÍCIES ESTRATIFICADAS	SUPERFÍCIES LACADAS	MADEIRA ENVERNIZADA	TEXTÍLIS PELES
ÁGUA COM SABÃO (SABÃO NEUTRO)	○	○	○	○	○
ÁGUA COM DETERGENTE		○	○		
INSTRUÇÕES ESPECÍFICAS DO FABRICANTE					○

## HRVATSKA

### UPUTE ZA MONTAŽU :

- 1 > PAŽLJIVO PROČITAJTE UPUTE ZA MONTAŽU
- 2 > PRIPREMITE SVE DIJELOVE NAMJEŠTAJA
- 3 > PRIKUPITE I PROVJERITE OKOVE ZA MONTAŽU
- 4 > PRIPREMITE POTREBAN ALAT
- 5 > PRIPREMITE PROSTOR ZA MONTAŽU
- 6 > POČNITE MONTIRATI

  
NEMOJTE UPOTREBLJAVATI SILU PRILIKOM SKLAPANJA  
NAKON NEKOG VREMENA PONOVRNO PRITEGNETE VIJKE  
ČUVAJTE UPUTE ZA MONTAŽU  
U SLUČAJU NEDOSTATKA NEKOG DIJELA NAJBOLJE ĆE BITI  
DA KONTAKIRATE PRODAJNO MJESTO

### UPUTE ZA ODRŽAVANJE :

- 1 > PAŽLJIVO OBRISATI PRAŠINU
- 2 > PREBRISATI ČISTOM, MEKOM TKANINOM NAVLAŽENOJ U BLAGOJ OTOPINI SAPUNA ILI DETERDŽENTA

  
-ZABRANJENA JE UPOTREBA KEMIKALIJA  
ILI BILO KAKVIH POMOĆNIH SREDSTAVA  
ZA RIBANJE JAKIH SREDSTAVA ZA ČIŠĆENJE  
ILI ČELIČNE VUNE  
-ZABRANJENO JE ČIŠĆENJE SA PREVIŠE  
VOĐE/VLAGE

	PAPIR	LAMINAT	LAK	DRVO	TEKSTIL/KOŽA
OTOPINA SAPUNA	○	○	○	○	○
OTOPINA DETERDŽENTA		○	○		
NAMJENSKA SREDSTVA					○

## TÜRKÇE

### MONTAJ TALİMATLARI :

- 1 > Montaj tanıtım yazısını dikkatlice okuyunuz.
- 2 > Mobilyanızı oluşturan parçaları işaretleyiniz.
- 3 > Hirdavatla ilgili parçaları bir araya toplayıp; kontrol ediniz.
- 4 > Gereken araç ve gereci tedarik ediniz.
- 5 > (Kendinize) Bir montaj alanı edininiz.
- 6 > Monte etemeye başlayınız.

  
MONTAJLARI ZORLAMAYINIZ.  
BİRKAÇ KULLANIMDAN SONRA VİDALARI SIKIŞTIRINIZ.  
BİR PARÇANIN KAYBOLMASI DURUMUNDA  
MAĞAZANIZLADAKİ KOLAY İLETİŞİME GEÇEBİLMEZİNİZ İÇİN  
MONTAJ KULLANIM TALİMATINI SAKLAYINIZ.

### BAKIM TALİMATLARI :

- 1 > TOZUNU DİKKATLİCE ALINIZ.
- 2 > YUMUŞAK BİR BEZİ TEMİZ SU VE AZ MİKTARDA SABUNLA (DETERJAN) NEMLENDİRİNİZ.

  
ASLA AŞINDIRICI ÜRÜNLER  
KULLANMAYINIZ : ÇELİK YÜNÜ,  
SOLVENT...  
BOL SUYLA YIKAMAYINIZ.

	SÜS KAĞIDI	KATMAN YÜZEY	LAK YÜZEY	ÇİLALI TAHTA	TEKSTİL DERİ
SABUNLU SU (NÖTR SABUN)	○	○	○	○	○
DETERJAN KATILMIŞ SU		○	○		
ÜRETİCİYE ÖZGÜ BAKIM					○

## ENGLISH

### ASSEMBLY ADVICE :

- 1 > CAREFULLY READ THE ASSEMBLY INSTRUCTION.
- 2 > IDENTIFY THE COMPONENTS OF THE FURNITURE.
- 3 > GROUP AND CHECK THE HARDWARE.
- 4 > USE THE REQUIRED TOOLS.
- 5 > CREATE AN ASSEMBLY ZONE.
- 6 > MAKE THE ASSEMBLY.

  
NEVER FORCE THE CONNECTIONS.  
RE-TIGHTEN THE SCREWS AFTER FEW DAYS.  
PLEASE RETAIN THE AI LEAFLET FOR FUTURE REFERENCE.  
THE AI CONTAINS INFORMATION WHEN CLAIMING  
FOR MISSING PARTS.

### CLEANING ADVICE :

- 1 > CAREFULLY REMOVE THE DUST.
- 2 > USE A SOFT, CLEAN DAMP CLOTH WITH SOAPY WATER.

  
NEVER USE ABRASIVE PRODUCTS  
OR SOLVENTS.  
DO NOT APPLY EXCESSIVE PRESSURE  
WHEN USING THE DAMP CLOTH.

	PAPER DECOR	LAMINATED SURFACES	LACQUERED SURFACES	VARNISHED WOOD	LEATHER TEXTILE
SOAPY WATER (NEUTRAL SOAP)	○	○	○	○	○
WATER WITH DETERGENT		○	○		
SPECIFIC SUPPLIER CLEANING					○